

DESCRIPTION

AMC MODEL AGTN-0320-60DD-100 OPT.HS1uS IS A DIGITALLY CONTROLLED VARIABLE ATTENUATOR DESIGNED TO OPERATE BETWEEN THE 0.1 TO 20 GHz FREQUENCY RANGE, 0.3 TO 18 GHz OPTIMIZED.

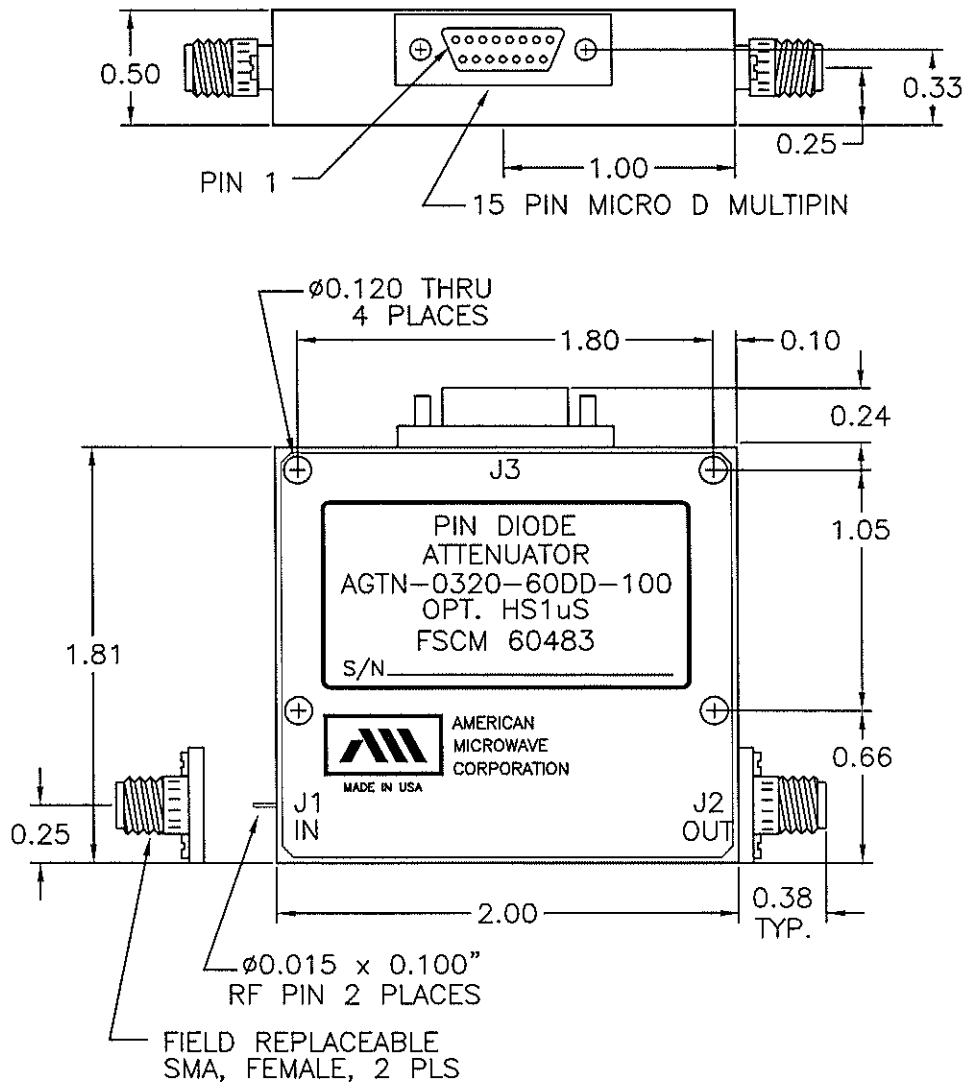

MECHANICAL OUTLINE

8 BIT TRUE BINARY LOGIC J3 PIN FUNCTIONS	
PIN NO.	FUNCTIONS.
1	GND
2	* N/C
3	* N/C
4	GND
5	0.25 dB
6	0.5 dB
7	1.0 dB
8	2.0 dB
9	4.0 dB
10	8.0 dB
11	16.0 dB
12	32.0 dB
13	+V
14	-V
15	* N/C

* N/C = NO CONNECTION

AMERICAN MICROWAVE CORPORATION

7311-G GROVE ROAD
FREDERICK, MARYLAND 21704 USA
TEL: 301-662-4700 FAX: 301-662-4938
WEBSITE: www.americanmicrowavecorp.com
E-MAIL: sales@americanmicrowavecorp.com
ISO 9001:2000 CERTIFIED



APPROVALS		DATE	TITLE			
DRAWN	<i>JDJ</i>	9/20/05	MECHANICAL OUTLINE AGTN-0320-60DD-100 OPT:HS1uS 0.1-20 GHz, DIGITALLY CONTROLLED VARIABLE ATTENUATOR 0.3-18 GHz OPTIMIZED FREQUENCY RANGE			
CHECKED	<i>LE</i>	9/20/06	SIZE	FSCM NO.	DWG NO.	REV.
RE-DRAWN	<i>PRB</i>	02/27/07	A	60483	100-A004-001	-
			SCALE N:S			SHEET 2 OF 4

ALL DIMENSIONS ARE IN INCHES
TOLERANCES:
X.XX ±0.020
X.XXX ±0.010

DESCRIPTION

AMC MODEL AGTN-0320-60DD-100 OPT.HS1uS IS A DIGITALLY CONTROLLED VARIABLE ATTENUATOR DESIGNED TO OPERATE BETWEEN THE 0.1 TO 20 GHz FREQUENCY RANGE, 0.3 TO 18 GHz OPTIMIZED.

FUNCTIONAL BLOCK DIAGRAM

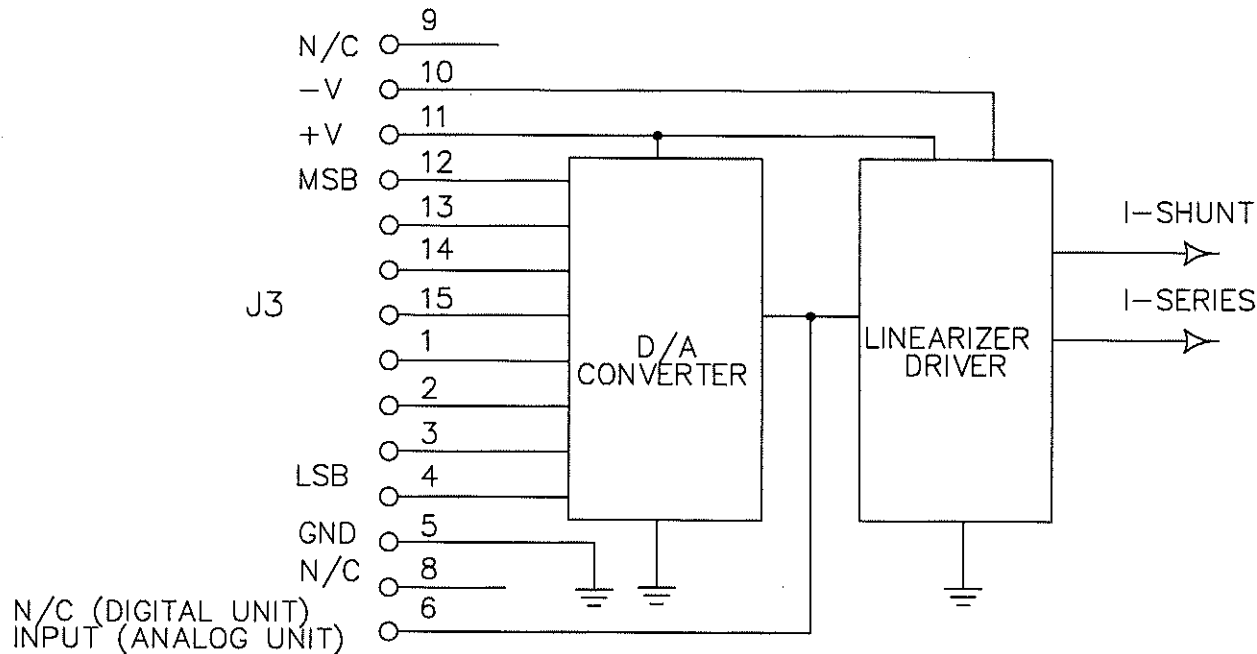

AMERICAN MICROWAVE CORPORATION

7311-G GROVE ROAD
 FREDERICK, MARYLAND 21704 USA
 TEL: 301-662-4700 FAX: 301-662-4938
 WEBSITE: www.americanmicrowavecorp.com
 E-MAIL: sales@americanmicrowavecorp.com
 ISO 9001:2000 CERTIFIED



APPROVALS		DATE	TITLE			
DRAWN <i>JDJ</i>		9/20/05	FUNCTIONAL BLOCK DIAGRAM			
CHECKED <i>LB</i>		9/20/06	AGTN-0320-60DD-100 OPT:HS1uS			
RE-DRAWN <i>PRR</i>		02/27/07	SIZE	FSCM NO.	DWG NO.	REV.
			A	60483	100-A004-001	-
			SCALE	N:S		SHEET 3 OF 4